

The repairable surface

Deep scratches, holes, burns or other surface damage can be easily and effectively repaired, without leaving any visible trace or affecting the original characteristics of the floor. This genuine, 100% repairable surface is unique to Colorex EC and Colorex SD and something that no other flooring system can promise.

Invisible repairs

Deep scratches and other serious damage can be repaired by heat welding. A small strip of Colorex of the same colour should be welded directly into the damage using a hand welding machine. After the excess material has been trimmed off, the repaired spot can be restored to a good-as-new condition by sanding and dry polishing.

- **Unique 100% repairable surface**
- **Scratches or serious damage can be solved**
- **It will be restored to a good-as-new condition**

Repair

Problem: Deep and long scratches, holes and burns

Advantage: Invisible repairs without damaging the initial characteristics of the product

Reason: Perfect homogenous product with low plasticizer content



Damage

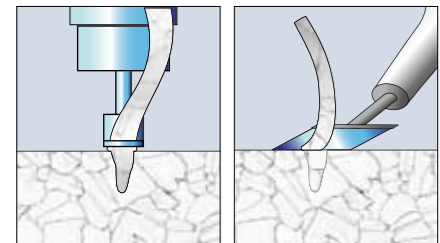

Heat welding and material trimming

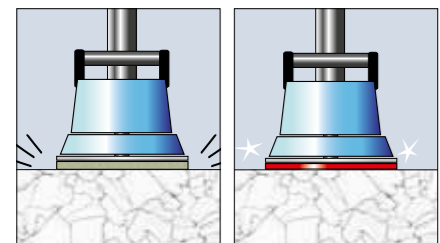

Sanding and dry polishing

Maintenance

Surface damage such as burns, excessive wear or discoloration from colouring chemicals can be removed by sanding with a conventional eccentric sander. Use a sand paper grade of 80 to start with and thereafter grades of up to 240. After sanding, the surface can be restored to its original quality and appearance by dry polishing with a red pad.

- **Easy sanding with conventional equipment**
- **Restore to its original quality and appearance by simply polishing**

Abrasive cleaning

Problem: Surface damage like burns, abrasion or staining

Advantage: Abrasive cleaning possible

Reason: Thanks to a compact high pressure pressed surface a PUR treatment is not necessary

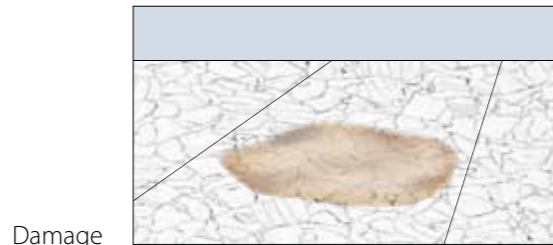

Damage

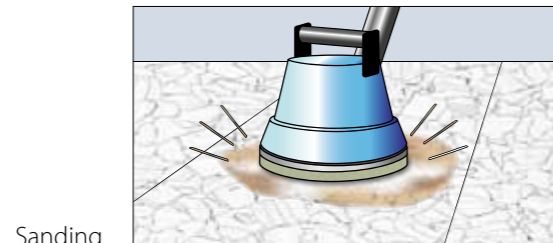

Sanding

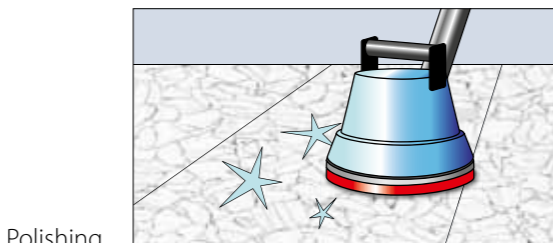

Polishing

Forbo Flooring Systems is part of the Forbo Group, a global leader in flooring, bonding and movement systems, and offers a full range of flooring products for both commercial and residential markets. High quality linoleum, vinyl, textile, flocked and entrance flooring products combine functionality, colour and design, offering you total flooring solutions for any environment.

Australia
Forbo Floorcoverings Pty Ltd.
23 Ormsby Place
Wetherill Park
NSW 2164
T +61 2 9828 0200
F +61 2 9725 3456
info.au@forbo.com
www.forbo-flooring.com.au

Baltic States
Forbo Flooring
K. Ulmana gatve 5
Riga, LV-1004, Latvia
Tel: +371 670 66 116
Fax: +371 670 66 117
info.lv@forbo.com
www.forbo-flooring.lv
www.forbo-flooring-ee.com
www.forbo-flooring.lt

China
Forbo Flooring China
6 Floor, Ansheng Business Center
No. 77 Fenyang Road
Shanghai 200031
P. R. China
Tel: 0086 21 6473 4586
Fax: 0086 21 6473 4757
info.cn@forbo.com
www.forbo-flooring.com.cn

Hungary, Romania
Forbo Flooring B.V. Hungarian Sales
Representative Office
125 Erzsébet királyné útja
1142 Budapest
Tel: +36 1 7858 073
Fax: +36 1 789 0636
info.hungary@forbo.com
www.forbo-flooring.hu

Korea
Forbo Flooring Korea
#207 Koryo B/D
88-7 Nonhyun-dong
Kangnam-gu, 135-818
Seoul, Korea
Tel: 82 2 3443 0644
Fax: 82 2 3443 0284
info.flooring.kr@forbo.com
www.forbo-flooring.co.kr

Middle-East, Africa, Turkey, Greece, French overseas
Forbo Flooring Systems
63, rue Gosset – BP 2717
51100 REIMS Cedex
France
Tél. 00 333 26 77 35 00
Fax 00 333 26 07 18 93
info-produits@forbo.com
www.forbo-flooring.com

New Zealand
Forbo Flooring Systems
PO BOX 230 265
Botany 2163 Auckland
T +64 0800 000 563
F +64 0800 000 634
info.nz@forbo.com
www.forbo-flooring.co.nz

Other countries
Forbo Flooring B.V.
P.O. Box 13
1560 AA Krommenie
The Netherlands
Tel: +31 75 647 74 77
Fax: +31 75 647 77 01
contact@forbo.com
www.forbo-flooring.com



Serbia, Croatia, Bulgaria, Bosnia and Herzegovina, Slovenia, Macedonia, Montenegro, Albania
Mobile: + 381 63 617 716
Email: boris.akerman@forbo.com

South East Asia
Forbo Flooring
190 Middle Road, #19-05
Fortune Centre
Singapore 188979
Singapore
Tel: + 65 6852 9805
Fax: + 65 6759 9212
info.flooring.sg@forbo.com
www.forbo-flooring.com

Taiwan/Hong Kong/Macau
Forbo Flooring
Tel: +852 9039 0708
info.flooring.tw@forbo.com
www.forbo-flooring.com

131672/010911

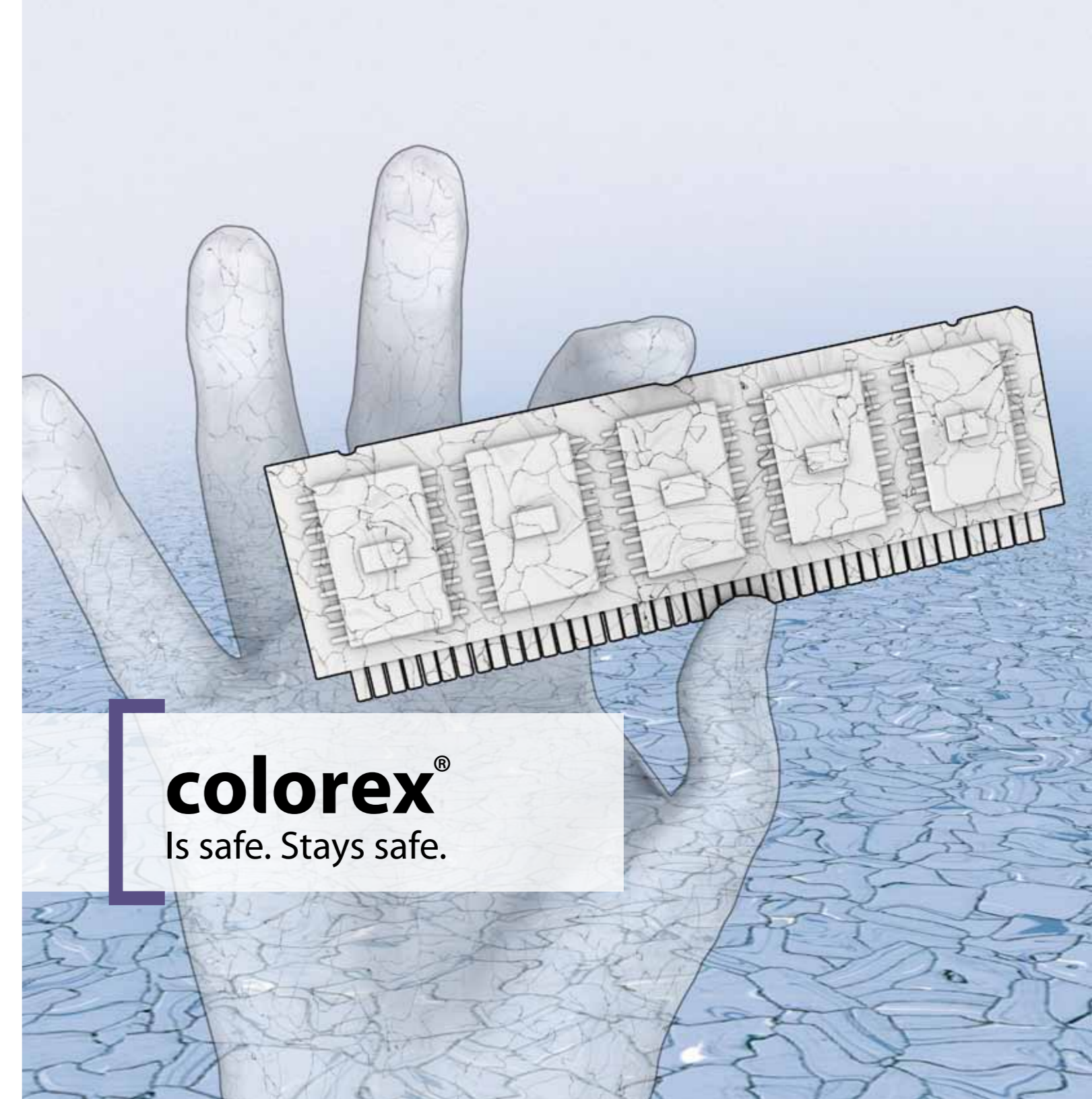

colorex[®]
Is safe. Stays safe.

forbo
FLOORING SYSTEMS

creating better environments

creating better environments

forbo
FLOORING SYSTEMS

Is safe. Stays safe.

Colorex is a high-performance flooring system that you can rely on. It is the ideal solution for ESD, cleanrooms, health care and industry. It provides a long life and consistent high quality – no matter the demand of the application. Colorex is a unique system of components to form the safest floorcovering once installed.

The right choice for a flooring system can enhance your interiors with innovative and beautifully designed products. However, for some applications your decision cannot be made on looks alone and the flooring you choose must also comply with the complex flooring requirements for technical areas.

Just be sure

Forbo Flooring has experience in every kind of flooring. You can just be sure that you are making the right choice when it comes to Colorex. It is the best known brand in ESD and cleanroom flooring for over 35 years. You do not have to wonder whether it matches your needs, we comply to every standard and norm so you can simply specify the colour you want. The standards of tomorrow are already compliant with the product of today.

Environmental profile

Based on our environmental policy we are constantly seeking for improvements to follow our compliant plus strategy which goes beyond official regulations. Our Colorex collection contains 15% post-industrial recycled content, we do not add any listed chemicals to produce our products.

The 7 certainties of Colorex

ESD flooring, Cleanrooms and Pharma, Operating theaters, Industry or Datacentre, Colorex is the right floor with the right properties; especially made for these purposes.

We offer:

- 1 A full match and exceeding all ESD and cleanroom standards**
- 2 Life time conductivity warranty**
- 3 The highest hygienic properties, high density and porefree**
- 4 Unique dimensional stability**
- 5 The advantages of low plasticiser content, resulting in an extreme low emission**
- 6 Full reparability and stain removal**
- 7 Resistance to heavy load**

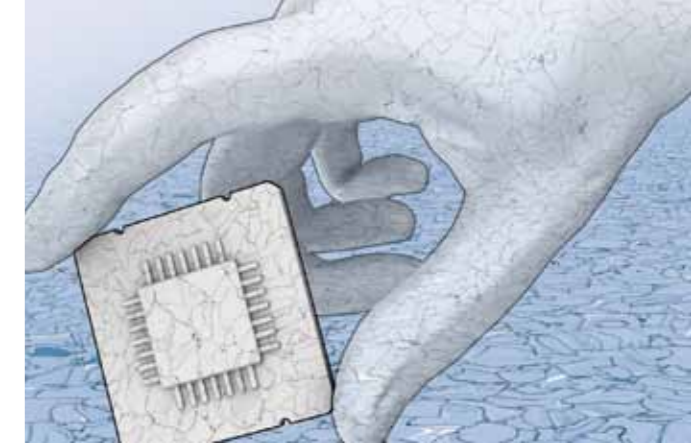

ESD flooring

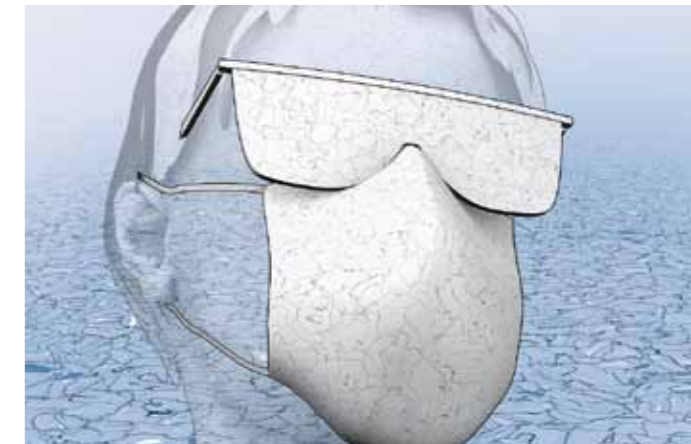

Cleanroom flooring

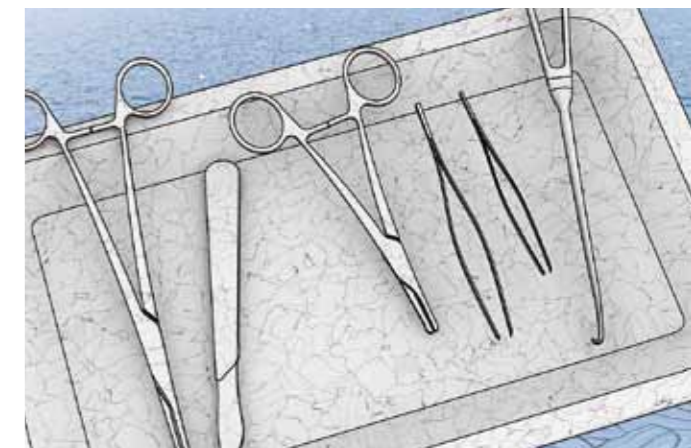

Health care flooring

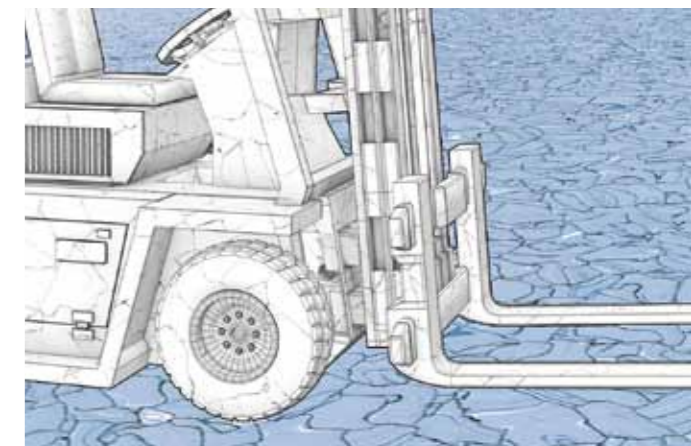

Industrial flooring

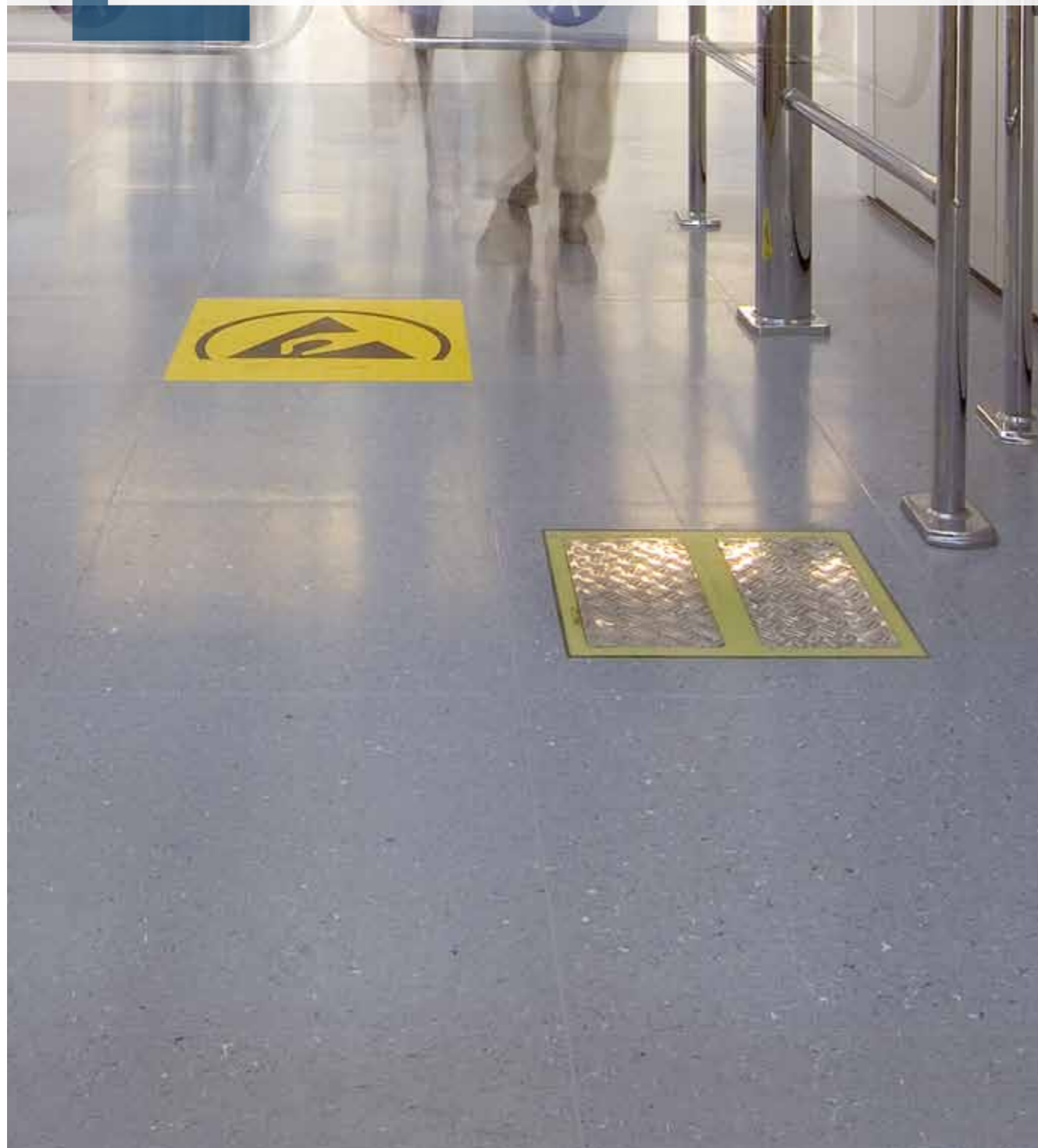

We start where others stop

We make tiles in order to ensure consistent and unique properties and to overcome problems that can be fatal like emission, shrinkage and diminishing of conductive properties. Tiles can be installed more quickly and easily than sheets and with less waste, especially in small and medium areas or rooms with irregular shapes.

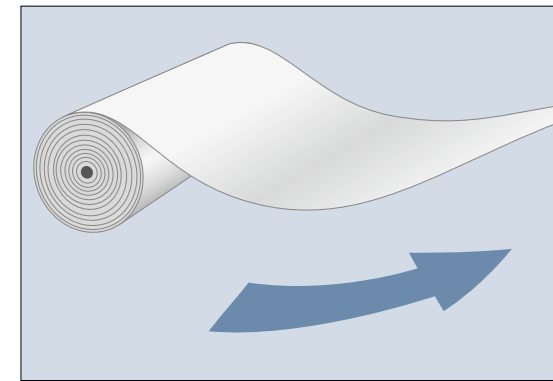

The process starts as a sheet but Colorex is only available in tiles and not without a reason. We are the only manufacturer of ESD and cleanroom flooring that can make a product that has advantages of both tiles and sheet in one product.



Construction Colorex

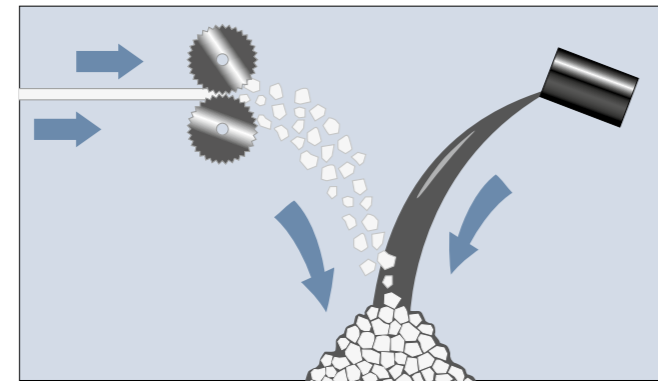
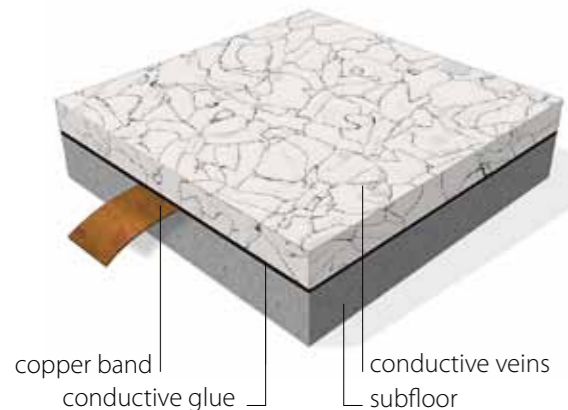

Step 1: Cut and conductive coatings
Cutting vinyl sheet into small chips, which are then coated with a conductive substance.

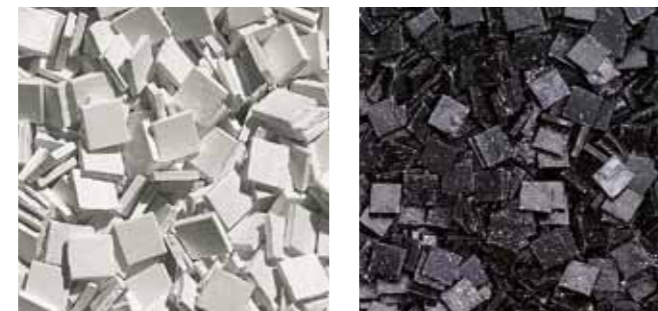

Advantages

- The chips mix creates the unique electro dissipative properties
- The chips guarantee a longlife conductivity independently from humidity and temperature

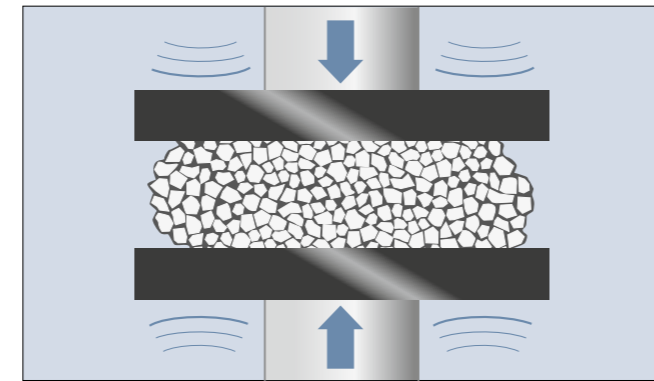

Step 2: Highpressure production
By applying very high pressure and a high temperature, these coated chips are then compressed into solid blocks of homogeneous material.

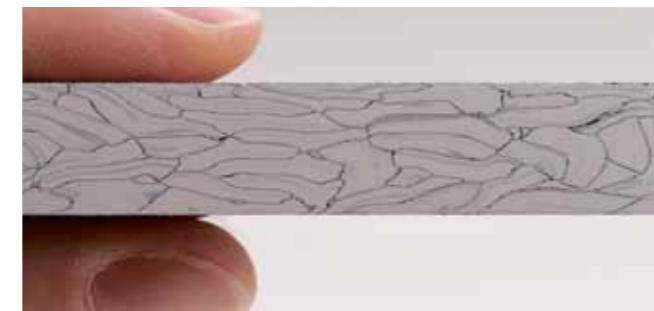

Advantages

- Take a look at the semi-finished product and you'll see that the conductive coating forms a dense network of tiny black veins
- These are the 'conductor paths' that enable safe electrostatic discharge through the whole thickness of the tile

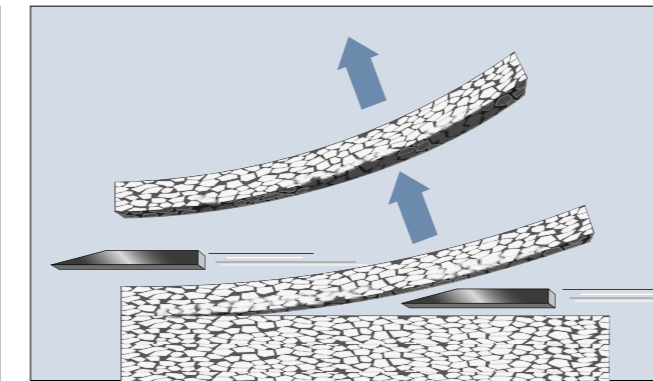

Step 3: Splitting and surface treatment
The extremely compressed blocks are cut into tiles.



Advantages

- The tiles are easy to work with and make a quick installation possible even without down time
- The easy-clean surface is pore free, making it suitable for the most stringent hygiene requirements, right up to certified cleanrooms
- Colorex is a highly compressed tile with a compact surface

The Colorex system

Colorex can be used everywhere. It can be installed by directly glueing it on concrete, as part on top of a raised floor panel or as a loose lay tile system. All versions come in two levels of conductivity EC Highperformance and SD Performance. The loose lay version additionally has an anti static (basic plus) and slip resistant (R11 plus) version to complete the high tech solutions offer.

Highperformance			
1 2 3	Functionality	Colorex EC Permanently conductive	Colorex EC plus Permanently conductive
	Description	Permanently conductive floor, connection between tiles through conductive adhesive and connected to earth through copper strip. Compliant to person-shoefloor-system requirement.	Permanently conductive floor, connection between tiles through dovetails and connected to earth with copper strip. Compliant to person-shoefloor-system requirement.
	Application area	New built ESD facilities, cleanrooms, pharmaceutical laboratories, production sites and operating theatres.	Renovation of ESD facilities, cleanrooms, pharmaceutical laboratories and production sites. Suitable when down time or raising moisture are critical.

Performance			
1 2 3	Functionality	Colorex SD Permanently static dissipative	Colorex SD plus (on request only) Permanently static dissipative
	Description	Permanently static dissipative floor, connection between tiles through conductive adhesive and connected to earth through copper strip.	Permanently static dissipative floor, connection between tiles through dovetails and connected to earth with copper strip.
	Application area	New built laboratories clean rooms, pharmaceutical laboratories, production sites and operating theatres.	Renovation of laboratories clean rooms, pharmaceutical laboratories and production sites. Suitable when down time or raising moisture are critical.

Standard			
1 2 3	Functionality	Colorex Basic (on request only) Resistant / repairable	Colorex Basic plus Resistant / repairable
	Description	Excellent chemical resistant, floor can be repaired in case of heavy damages.	Excellent chemical resistant, floor can be repaired in case of heavy damages.
	Application area	New built shops, stores, warehouses. Areas with high traffic needing daily intensive cleaning.	Renovation of shops, stores, warehouses. Areas with high traffic needing daily intensive cleaning. Suitable when down time or raising moisture are critical.

Colorex EC Highperformance

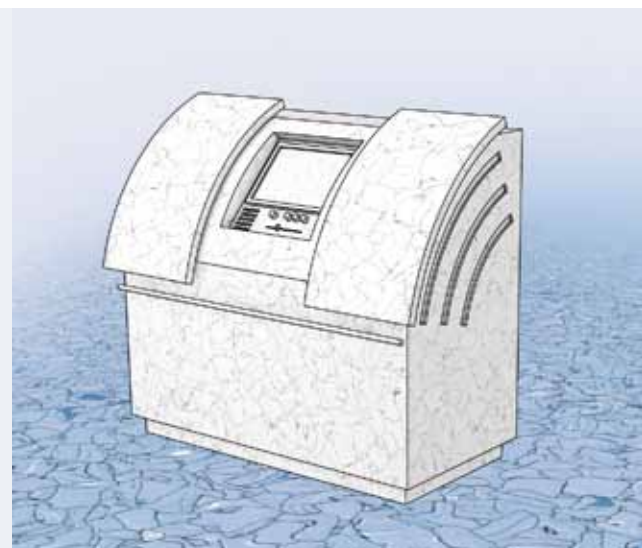
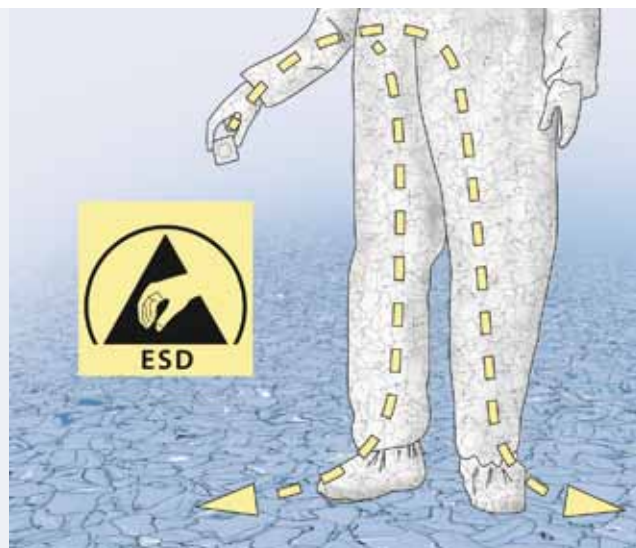

Colorex SD Performance

Colorex EC plus Highperformance

Colorex SD plus
(only available on request)

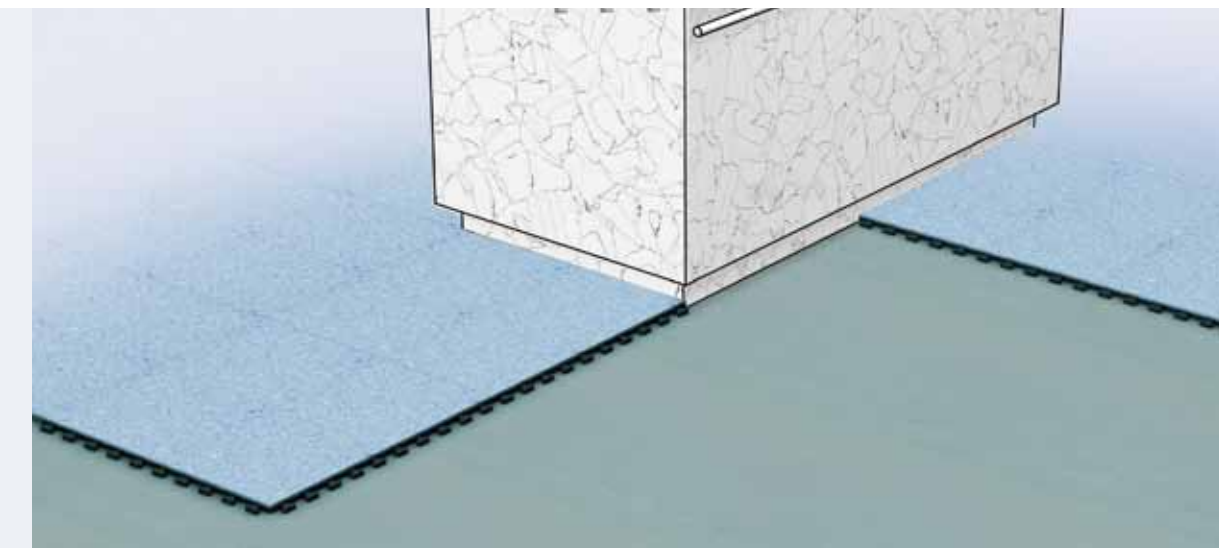

With Colorex EC static charges flow easily through the dense network of tiny conductive veins in the whole thickness of the tile. These are collected by the conductive adhesive and securely discharged to earth via the copper strip. It's a completely natural system that needs no volatile, chemical anti-static additives to aid conductivity. The conductivity is completely independent from moisture in the air.

- Functionality:** Permanently conductive
- Description:** Permanently conductive floor, connection between tiles through conductive adhesive and connected to earth through copper strip. Compliant to person-shoefloor-system requirement.
- Application areas:** ESD facilities, cleanrooms, pharmaceutical laboratories, production sites and operating theatres.

Colorex SD enable safe electrostatic discharge through the whole thickness of the tile. The conductive coating forms a dense network of tiny black veins.

- Functionality:** Permanently static dissipative
- Description:** Permanently static dissipative floor, connection between tiles through conductive adhesive and connected to earth through copper strip.
- Application areas:** New built laboratories clean rooms, pharmaceutical laboratories, production sites and operating theatres.

Renovating an industrial flooring can be a very costly and labour intensive endeavour. The downtime needed to move or disassemble heavy production equipment and the cost of a complex subfloor renovation can begin to add up before work on installing the new floor has even started. Colorex EC plus is a high performance floor covering system that consists of loose lay tiles. Suitable for applications where

expensive preparatory measures and downtimes are not acceptable, it can be installed without interruptions and is immediately accessible. There's no need for special subfloor treatments or preparations. The tiles connect to each other using a unique dovetailing system that remains hidden. But because they have a genuine Colorex surface you can still take advantage of its proven features and benefits.

- Functionality:** Permanently conductive
- Description:** Permanently conductive floor, connection between tiles through dovetails and connected to earth with copper strip. Compliant to person-shoefloor-system requirement.
- Application areas:** Renovation of ESD facilities, cleanrooms, pharmaceutical laboratories and production sites. Suitable when down time or raising moisture are critical.



Finishing solutions

In highly sensitive health care areas, and anywhere that has strict hygiene requirements, it's vital that floor-to-wall transitions are water-tight, perfectly hygienic and aesthetically pleasing. Our integrated coving system creates a perfect seal for these critical areas using the same Colorex material.

Cove skirting strip in rolls

The cove skirting is cut and welded from the original colorex tiles assuring quality from wall to wall.

12,2 m Long, standard height 15 cm
(5 cm on the floor plus 10 cm up the wall)



Pre-formed internal and external corner pieces

The corners are moulded from original Colorex and reinforced to assure the best possible result and making sure the most critical parts are manufactured in a controlled environment. Welding is not required. Including resin reinforcement on the back.

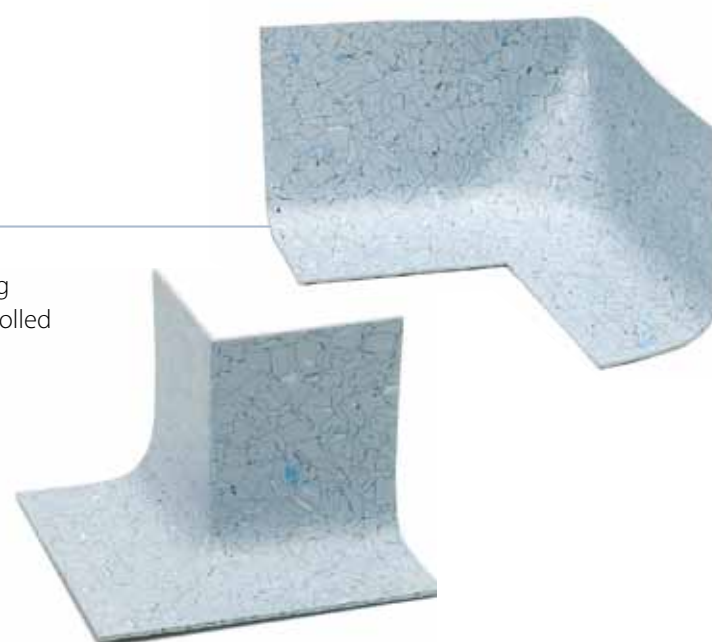

Skirting for Colorex plus

There are two types of skirtings available for our Colorex plus versions. Either a full hygienic solution with tailor made coving or a solution to prevent raising moisture.

Radius 20 mm



Colorex ramp

Colorex plus may be installed as a working island or may not end on a wall. Access ramps are available in grey, in colour matching or as signal colours on request.



Colorex welding rods

All the accessories on this page and Colorex tiles can be welded with Colorex welding rod, available in matching colours.

In standard 4 mm diameter and 100 m coils



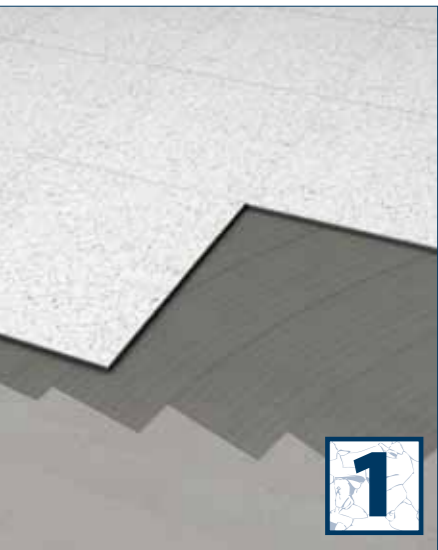

Colorex glued to the floor

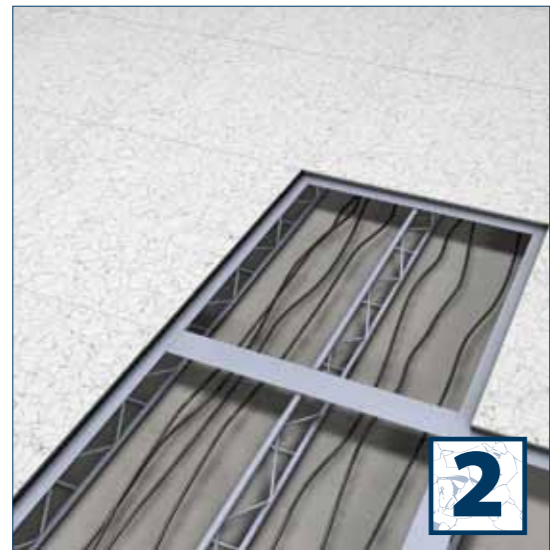

Colorex on top of a raised floor panel

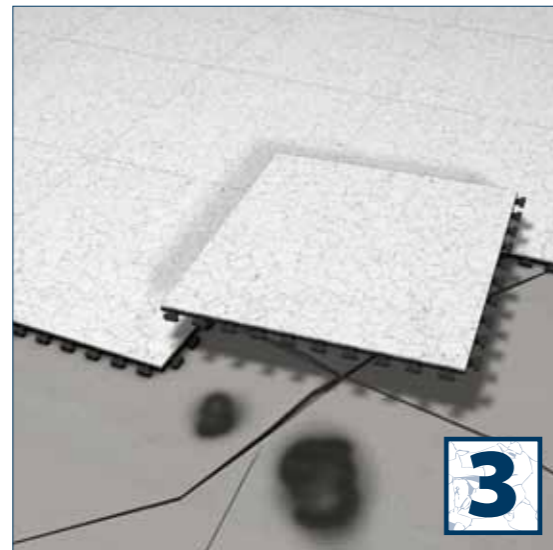

Colorex as loose lay tile

Colorex Basic plus Standard

Colorex Basic
(only available on request)

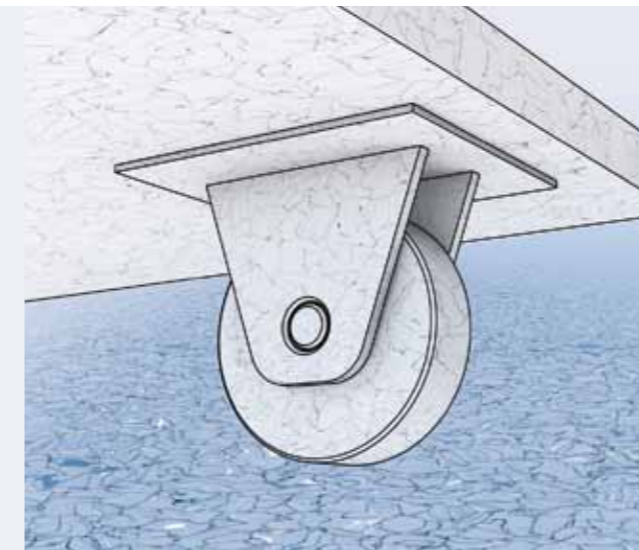

R11 plus

1. Colorex glued to the floor

Colorex can be installed on a concrete subfloor. This is often done using a conductive primer first after which copper tape and conductive adhesive is applied. When Colorex is placed on top the copper tape drains the electrical charges to the earth where it will be connected to. When conductivity is not required the normal primer and adhesive is used. Installed on concrete Colorex can withstand heavy loads like fork lift trucks without damaging the floor itself. Welding of tiles is optional for ESD areas. For cleanrooms it is a requirement. For these areas it is good to know that since Colorex tiles do not shrink, a correctly installed weld will never open up.

2. Colorex on top of a raised floor panel

Often Colorex is placed on a raised floor panel that is used in cleanrooms or datacenters. Due to the strength and unique properties of Colorex raised floor manufacturers can make every possible construction with Colorex depending on the area of use. Since Colorex has extreme low emission and a high density it can be perforated for air flow systems that are often used in combination with raised floors. Heavy traffic and reparability without losing visual appearance make Colorex stand out against any other alternative.

3. Colorex as loose lay tile

Colorex plus is a high performance floor covering system consisting of loose lay tiles for all those areas of application where expensive preparatory measures and downtimes are simply excluded. A specific treatment or preparation is not necessary as long as the floor is flat. Colorex plus can be installed without stopping or disturbing current activities and is immediately accessible. With its honeycomb structure at the bottom Colorex plus can even ventilate humidity when needed while in use. The Colorex plus tiles are connected together by a unique dovetailing system that remains hidden under the surface and they are featuring a genuine Colorex surface with its proven features and benefits. Colorex plus is available as an Electrical Conductive (EC) Highperform version. On request it can be ordered as a Static Dissipate (SD) perform version. Additionally there is an antistatic version for non conductive installations. On top of this the system is completed with a slip resistant tile that can be connected to all the types of Colorex plus tiles for heavy duty areas. With Colorex plus specially developed ramps and skirtings can be used to form a complete solution for any type of situation. Even fork lift trucks form no problem for Colorex plus.

Colorex Basic plus is a loose lay floor covering system with Colorex on top without conductive properties. This ensures all the benefits of Colorex like high density, easy repair and stain resistance. But also combines the benefits of a heavy duty loose lay tile.

Functionality: Resistant / repairable

Description: Excellent chemical resistant, floor can be repaired in case of heavy damages.

Application areas: Shops, stores, warehouses. Areas with high traffic needing daily intensive cleaning.

Enhanced slip resistance, R11 plus have a strong surface embossed structure and have a high slip resistance R11 to meet safety requirements.

Functionality: Slip resistant

Description: Dirt hiding, slip resistant floor.

Application areas: Industrial areas, garages, warehouses. Suitable when down time or raising moisture are critical.

		R11 plus
Functionality		Slip resistant
Description		Dirt hiding, slip resistant floor.
Application area		Industrial areas, garages, warehouses. Suitable when down time or raising moisture are critical.



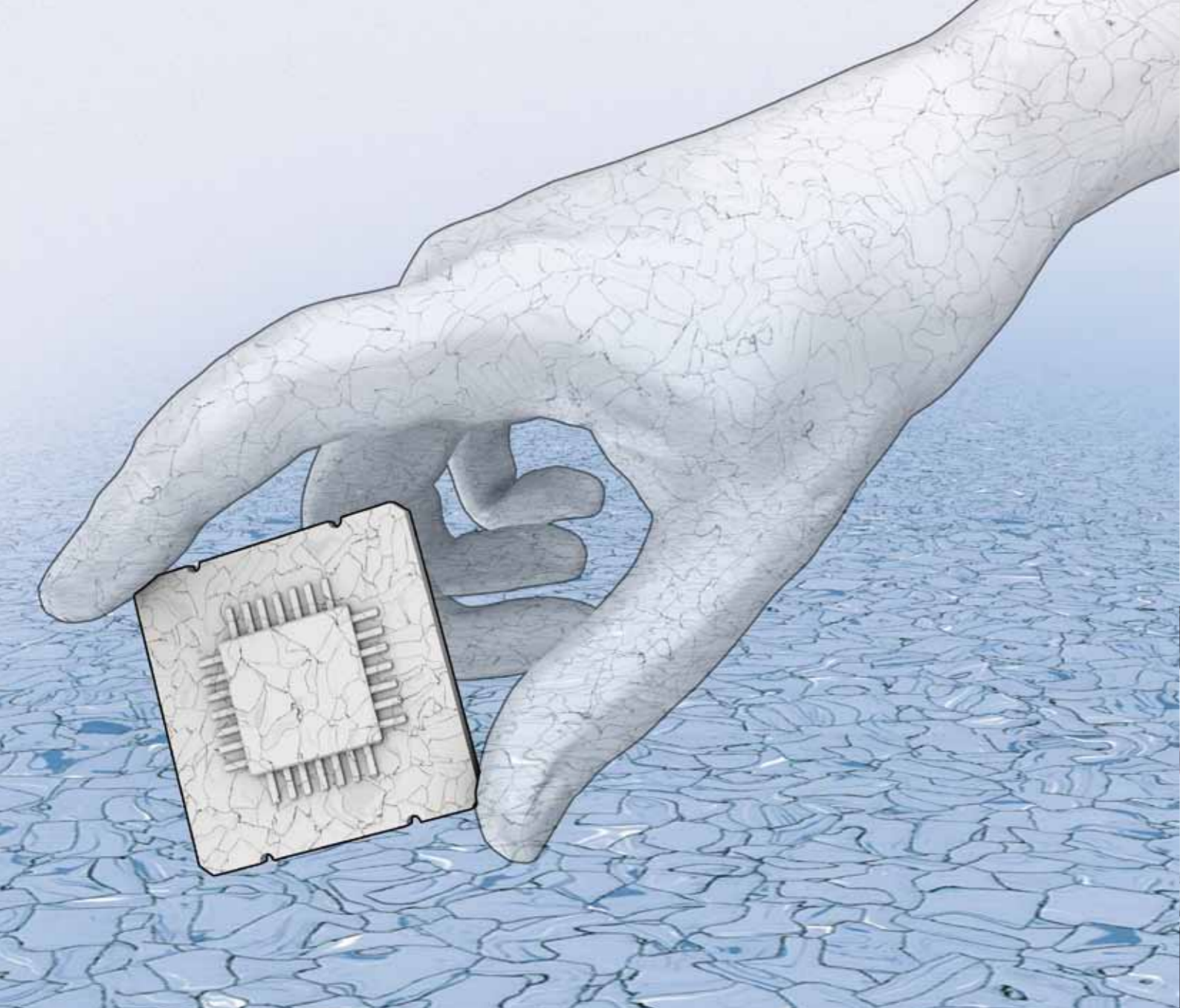

ESD flooring that's future proof

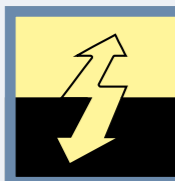

Lifetime
Conductivity
Warranty



Electrostatic
Discharge Flooring
(ESD)

Products:
• Colorex EC

The right floor makes the difference

Reducing the generation of electrostatic charges is the main purpose of control measures in ESD protected areas (EPA). In such areas like electronics assembly, mechatronics and datacenters the right floor covering plays a crucial role. It does not only drain electrostatic charges from personnel and equipment, but it also reduces the generation of charges there where they occur, at the interface between the shoe soles and the floor.

Consistent conductivity throughout life time

The unique construction of Colorex EC and Colorex SD, completely free from volatile antistatic chemicals, ensures a permanent and stable conductive performance of the floor over its entire life time, totally independent from humidity and temperature.

We guarantee more than resistance

Forbo Flooring guarantees highest safety. We measure the electrical resistance of every single production batch of Colorex EC and Colorex SD and deliver upon request a test report clearly showing the results of our measurements.

Low body voltage generation

It is a natural fact that anybody can accumulate electrostatic charge just by simple motion or walking. By wearing the appropriate ESD shoes however, these charges will be securely drained through the dense network of conductive veins of Colorex EC and Colorex SD.

Cleanroom flooring for the highest standards



Products:

- Colorex EC /-plus
- Colorex SD /-plus

In cleanroom environments in the pharmaceutical, life sciences and manufacturing industries, airborne particles can be a major source of contamination. Not only can they cause yield loss, the particles can also lead to corrosion and product degradation. ISO standards and cGMP regulations for air purity require you to comply by presenting consistent results that can be verified on a regular basis. Colorex can help here too. Ideal for cleanrooms in these kinds of environments, it satisfies the strictest requirements for particle release behaviour, helping to reduce any threat of contamination. What's more, following a comprehensive programme of testing, its suitability in cleanroom applications has been certified by the renowned Fraunhofer IPA Institute in Germany.

Colorex SD/EC was tested for the following:

- Airborne particle emission test and cleanroom suitability (ISO 14644-1)
- Outgassing analysis and classification (ISO 14644-8)
- Adhesion of microorganisms
- Assessment of microbial metabolic potential (ISO 846)
- Chemical resistance (ISO 2812-1)
- Cleanability rating (VDI guideline 2083 Part 4)
- GMP classification complying to Class A



Hygiene and safety for sensitive hospital areas

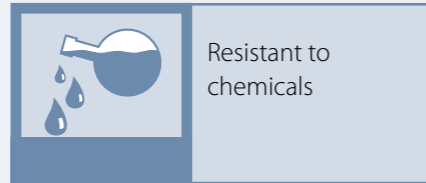
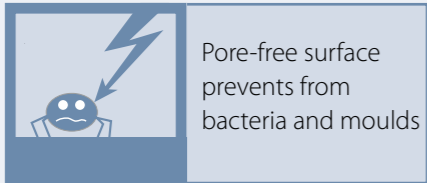

- Products:**
- Colorex EC /-plus
 - Colorex SD

A demanding area

In sensitive hospital areas such as operating theatres, intensive care units and imaging diagnostic facilities, flooring presents its own unique challenges. Not only must it comply with stringent hygiene regulations to help prevent hospital-acquired infections, it must also demonstrate that it meets any necessary safety requirements. And most importantly, it must prevent any electrostatic discharges as these can cause malfunctions, or even failures, in highly sensitive medical equipment and devices.

The highest standards of hygiene

Colorex satisfies all these requirements. Its conductive properties allow you to avoid the negative effects of an accumulation of static electricity. At the same time, the compact, pore-free surface is unfriendly to bacteria and moulds, helping you to maintain the highest standards of hygiene. And thanks to its excellent stability and consistent high quality, its aesthetic appeal won't be tarnished by the regular cleaning and disinfecting cycles that are imperative in hospital environments. Colorex is highly stain resistant helping to ensure your investment will still look good in years to come.

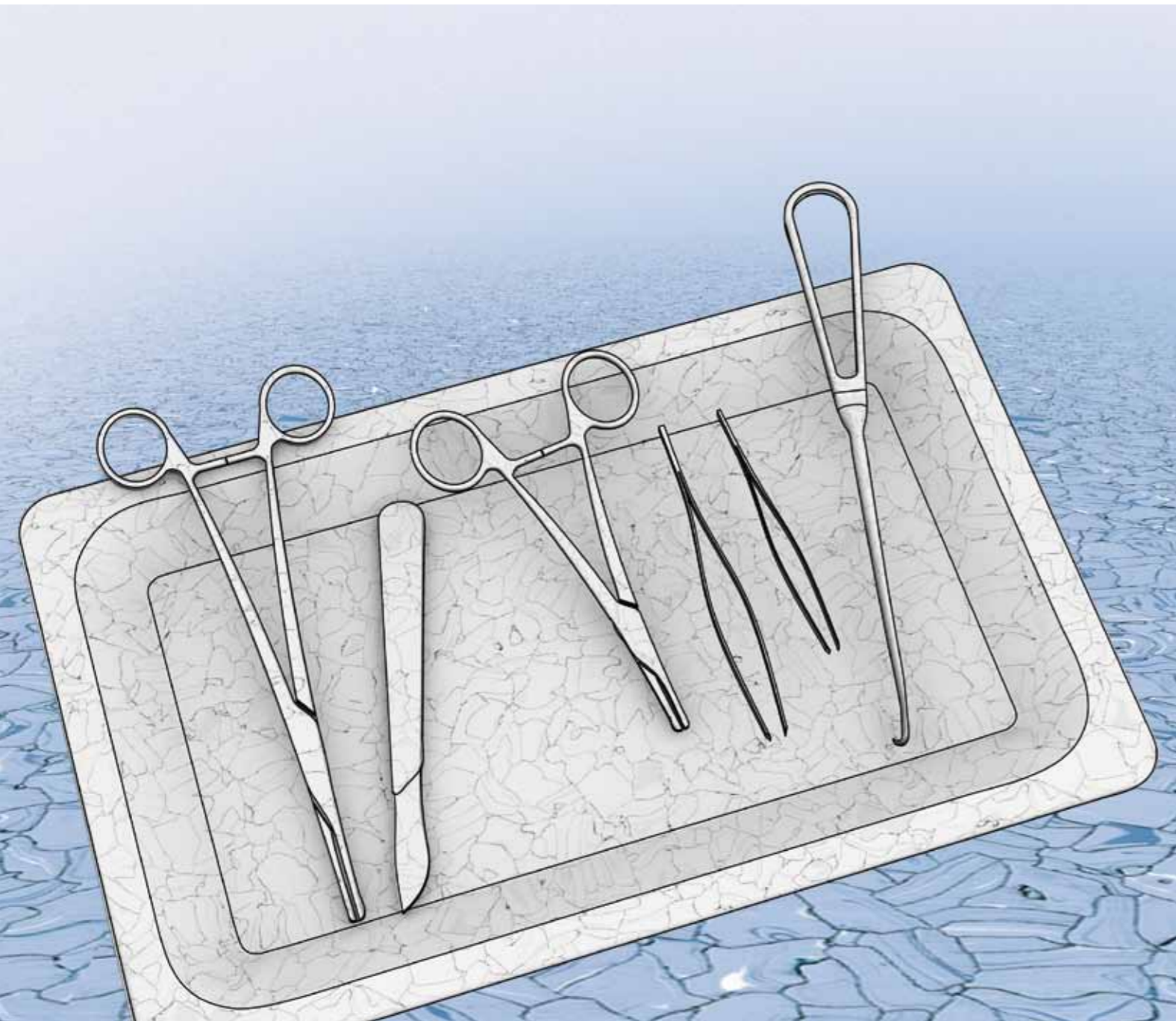

Industrial flooring for wear intensive areas

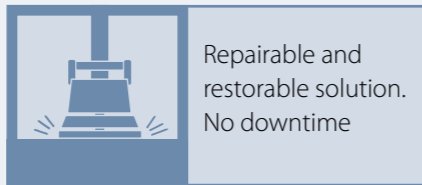
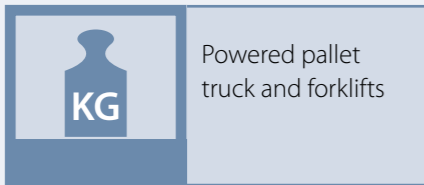

- Products:**
- Colorex SD /-plus
 - Colorex Basic /-plus
 - R11 plus

Suitable for the toughest settings

Industrial environments present their own flooring problems, particularly in areas with high wear and tear. Our Colorex high performance floor covering systems are designed for all industrial areas, including the toughest of settings. Cut from a homogeneous, solid block of highly compressed material they have a high vinyl content and a well balanced amount of mineral filler for optimum performance.

Colorex offers you:

- High mechanical resistance and wear with no need for factory coating or additional surface hardening treatments
- Excellent chemical resistance thanks to the pore-free surface and a remarkably low percentage of plasticiser
- A 100 % repairable and restorable solution that leaves no trace of abrasive treatment methods

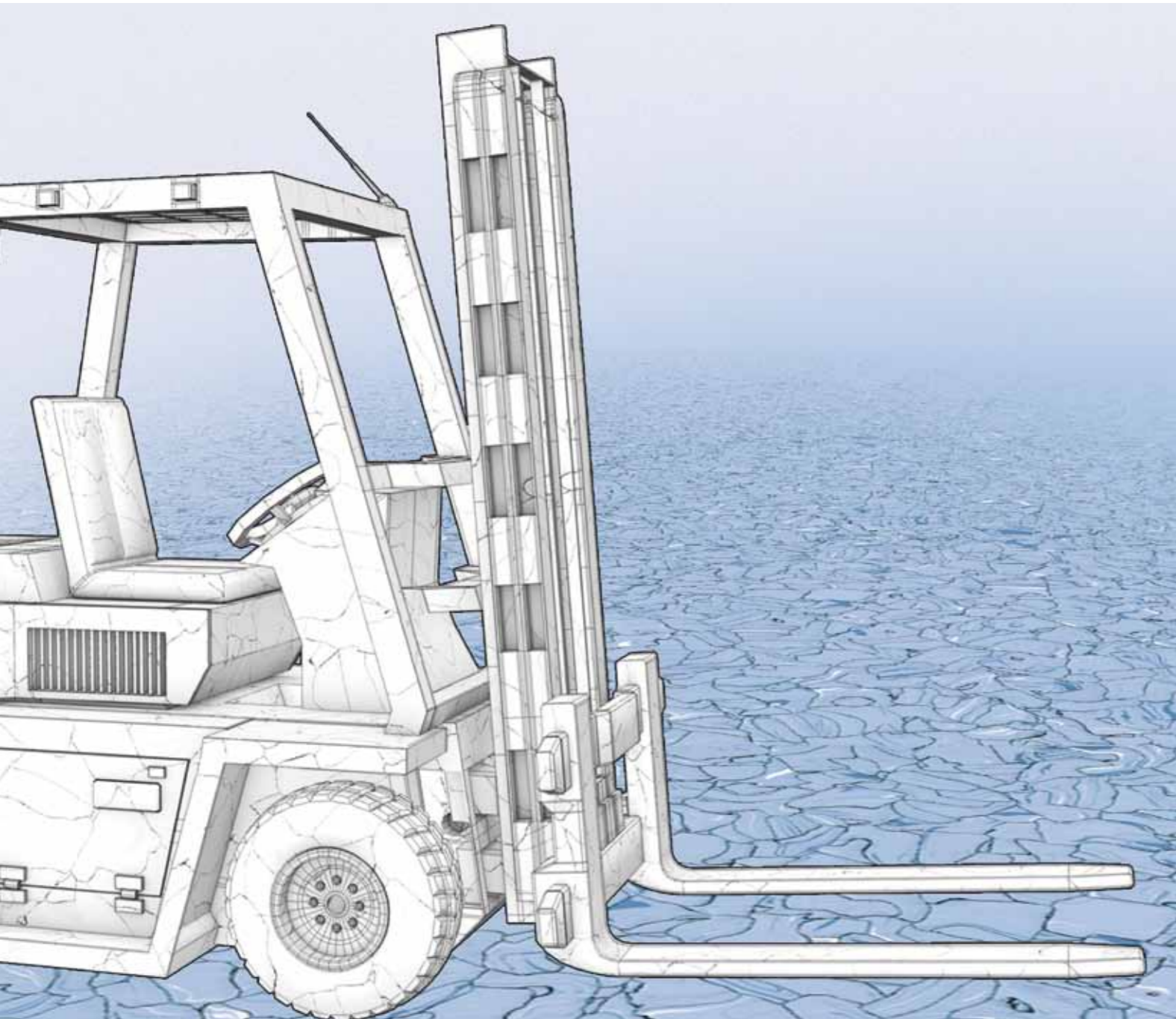

Inner and outer corners – hygienic and aesthetic

In sensible areas close wall plinths do not only look nice but are in many cases also a must from a hygienic point of view.

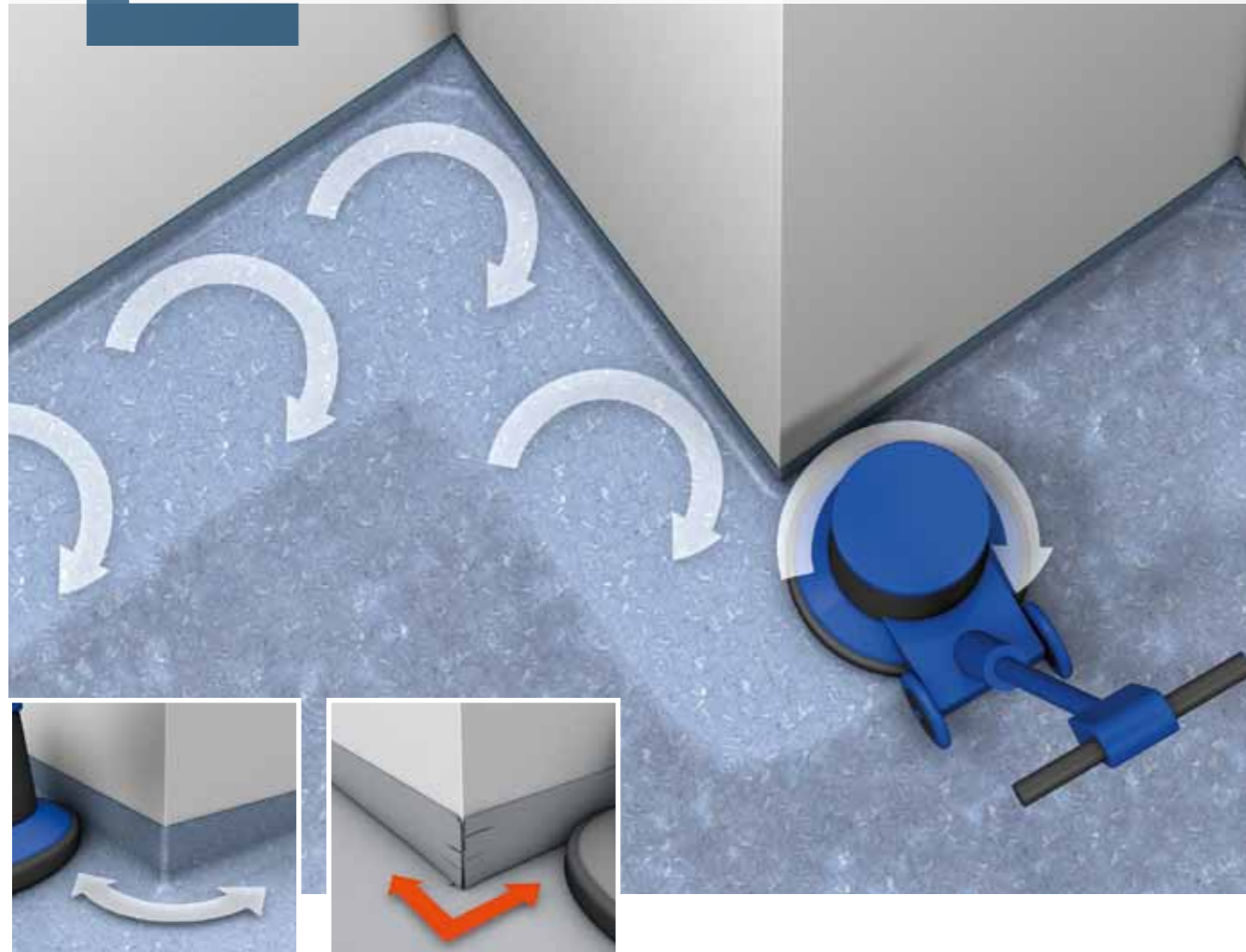









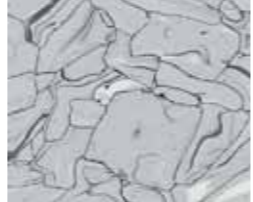



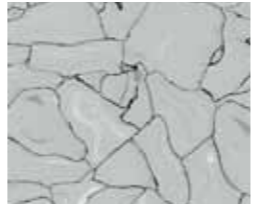
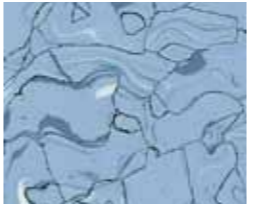



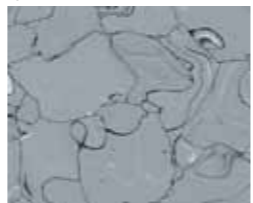
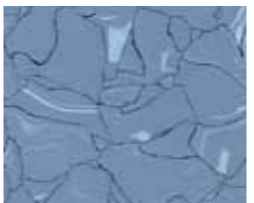
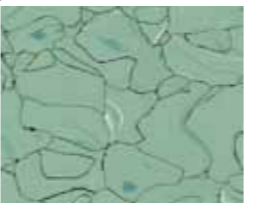

Corners and plinths are depending on quality, inferior products are dirty before you know it and show traces of bacteria. This is not the case with Colorex as it is thermally bonded. This multiple usable accessory offers you for such problem areas the perfect closing solution and with that the absolute freedom of the room design.

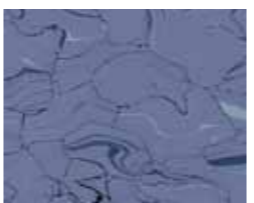
The Colorex accessories have amongst others preformed inner corners with a great radius which is linked to the size of the cleaning pads. This way the dirt collection of difficult to reach areas is prevented.

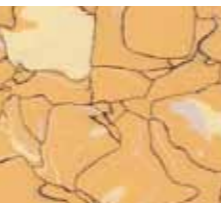
Preformed outer corners are prevented from tearing because of their special construction. The inner reinforcement prevents that the outer corners tear or break, due to high mechanical pressure, e.g. the rotation of a cleaning machine. While Colorex SD and EC are homogeneous material without additional backing material or strengthening layers it can be optimally combined with constructions like unequal walls. The well thought of accessories make the cleaning regime easy and guarantees a reliable durability - a real hygiene advantage.

Colorex collection

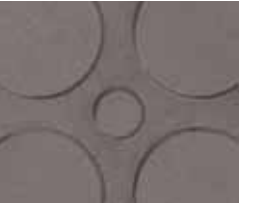
 SD 150201 EC 250201	 SD 150205 EC 250205 EC plus 621005 Basic plus 611005	 SD 150221 EC 250221	 SD 150225 EC 250225	 SD 150240 EC 250240
 SD 150203 EC 250203	 SD 150206 EC 250206	 SD 150222 EC 250222 EC plus 621022 Basic plus 611022	 SD 150234 EC 250234	 SD 150213 EC 250213 EC plus 621013 Basic plus 611013
 SD 150202 EC 250202	 SD 150207 EC 250207 EC plus 621007 Basic plus 611007	 SD 150223 EC 250223	 SD 150236 EC 250236	 SD 150215 EC 250215
 SD 150204 EC 250204 EC plus 621004 Basic plus 611004	 SD 150208 EC 250208	 SD 150224 EC 250224	 SD 150232 EC 250232	 SD 150219 EC 250219
 SD 150233	 SD 150235	 SD 150237	 SD 150231	 601060

Technical specifications Colorex

Colorex meets the requirements of EN 649

	Colorex SD	Colorex EC	Colorex EC Plus	Colorex Basic Plus	R11 Plus
CE CE marking	EN 14041	Compliant	Compliant	Compliant	Compliant
ASTM**	Compliant		Compliant		
Total thickness	ISO 24346 / EN 428	2.0 mm / 3.0 mm*	2.0 mm / 3.0 mm*	10.5 mm	10.5 mm
Tile size	EN 427	615x615 mm 615x1230 mm*	615x615 mm 615x1230 mm*	608x608 mm	608x608 mm
Commercial very heavy	ISO 10874 / EN 685	34	34	34	34
Industrial heavy	ISO 10874 / EN 685	43	43	43	43
Electrical resistance	IEC 61340-4-1 EN 1081 (100V) ANSI/ESD 7.1	10 ⁶ ≤ R ≤ 10 ⁷ Ω	5 x 10 ⁴ ≤ R ≤ 10 ⁵ Ω	2.5 x 10 ⁴ ≤ R ≤ 10 ⁵ Ω	n.a.
Electrical resistance in combination with ESD Shoes	IEC 61340-4-5 ESD STM 97.1	n.a.	R < 3.5 x 10 ⁷ Ω	R < 3.5 x 10 ⁷ Ω	n.a.
Outgassing	IDEMA M11-99	total < 1 µg/cm ²	total < 1 µg/cm ²	total < 2 µg/cm ²	total < 2 µg/cm ²
Total TVOC 28 days	AgBB guidelines	< 1 mg/m ³	< 1 mg/m ³	< 1 mg/m ³	< 1 mg/m ³
Total TSVOs 28 days		< 0.1 mg/m ³	< 0.1 mg/m ³	< 0.1 mg/m ³	< 0.1 mg/m ³
Bacteriostatic	SNV 195 920	Pass	Pass	Pass	Pass
Chemical resistance	ISO 26787 / EN 423	Excellent	Excellent	Excellent	Excellent
Slip resistance	DIN 51130	R9	R9	R9	R9
Total weight	ISO 23997 / EN 430	3.2 kg/m ²	3.2 kg/m ²	12.4 kg/m ²	12.4 kg/m ²
Dimensional stability	ISO 23999 / EN 434	0.05%	0.05%	n.a.	n.a.
Thermal dilatation coefficient		n.a.	n.a.	0.11 mm/m°C	0.11 mm/m°C
Residual indentation	ISO 24343-1 / EN 433	0.035 mm	0.035 mm	n.a.	n.a.
Resistance to loads (performance may vary, subject to local conditions)		n.a.	n.a.	Powered pallet truck and forklifts: total weight up to 2.5 t with hard wheels and up to 5 t with air tyres. Static loads: 50 kg/cm ² - dynamic loads: 90 kg/cm ²	
Abrasion resistance	EN 660-2	Group M	Group M	Group M	Group M
Castor chair continuous use	ISO 4918 / EN 425	no effect	no effect	no effect	no effect
Light fastness	EN ISO 105 B02	≥ 6	≥ 6	≥ 6	≥ 6
Impact sound reduction	EN ISO 140-8	2 dB	2 dB	12 dB	12 dB
CE EN 14041					
All Colorex products meet the requirements of EN 14041					
Body voltage generation, with appropriate ESD shoes	IEC 61340-4-5 ESD STM97.2 EN 1815	40 V	20 V	20 V	< 2 kV
Reaction to fire	EN 13501-1	B _s -s1	B _s -s1	B _s -s1	B _s -s1
Slip resistance	EN 13893	μ = 0.60	μ = 0.60	μ = 0.60	μ = 0.60
Thermal conductivity	EN 12524	0.28 W/(m·K)	0.28 W/(m·K)	0.28 W/(m·K)	0.28 W/(m·K)

* Available on request
** Product also tested to ASTM. Results available on request

The quality and environmental management system of Forbo Giubiasco S.A. (CH) where Forbo Colorex is manufactured are certified in accordance with ISO 9001 and ISO 14001

